

ROHDE 

| Arts and Crafts

Enjoy your **results.**

PRODUCT CATALOGUE 2017/18
KILNS AND MACHINERY
Ceramics and glass

WELCOME TO ROHDE

QUALITY
 SAFETY
 EFFICIENCY
 PASSION

	About ROHDE	4-5	
	Which is the right kiln?	6-7	
TOPLOADERS	Toploaders Details	8-11	
	Toploaders Ecotop	12	
	Toploaders TE-MCC+	13	
	Toploaders TE-S	14	
	Toploaders TE-Q and BT	15	
HOOD KILNS	Hood kilns HE	16	
	Toploaders Overview	17	
FRONTLOADERS	Frontloaders Details	18-21	
	Frontloaders KE-B	22-23	
	Frontloaders KE-N	24	
	Frontloaders KE-S	25	
	Frontloaders KE-S+	26	
	Frontloaders KE-SH	27	
	Frontloaders ELS Ergo Load System	28-29	
	Frontloaders Ergo Load System ELS-N	30	
	Frontloaders Ergo Load System ELS-S	31	
	Frontloaders Accessories and Overview	32-33	
GAS AND RAKU KILNS	Gas Kilns TG and KG	34-37	
	Raku Kilns TR and KR	38-39	
	Gas and Raku Burners	40-41	
FUSING KILNS	Fusing Kilns TE-MCC+ DH and Fusing	42-45	
	Fusing Kilns FE	46-47	
CONTROLLERS	Kiln Controllers	48-53	
	Pottery Wheel HMT 500	56	
MACHINERY AND EQUIPMENT	Pugmill TS 20	57	
	Slab Roller PW 600	58	
	Spray Booth SK 66	59	
	Banding Wheels	60-61	
	Sedimentation Basin AB 100	62	
	SERVICE	Delivery and Set-up Service, Warranty	64

For more than 35 years, ROHDE has been committed to customer and product benefits. This can be recognised when working with ROHDE kilns and machinery particularly when it comes to handling, efficiency, quality and results. Each day more than 100 employees make every effort to offer outstanding technology and performance. They contribute towards the best possible implementation of your creations, products and workpieces and allow you to show-off your expertise to the best advantage.

ROHDE
PROVEN
QUALITY

PEOPLE LIKE YOU
MOTIVATE US TO GIVE OUR BEST.

ROHDE is committed to sustainability and ecological awareness and attaches great importance to energy efficiency and product durability from choice of material to kiln operation. ROHDE's in-house production offers highest flexibility and performance from a single source. ROHDE has a network of local specialists serving the European market and guarantees fast supply of spare parts. The ROHDE delivery and set-up service provides safe on-site delivery of your kiln.

ROHDE supports and promotes arts and ceramics and is an active participant at symposia, workshops and the Diessen Ceramic Award. ROHDE employees are highly motivated to offer you technical lead and advantages in all fields of ceramics. Benefit from smooth processes and efficient workflows when it comes to the consultation as well as the development, construction and manufacture of your kiln, as well as sales and all other services and enjoy your results.



“WE ARE COMMITTED TO OFFERING A TECHNOLOGICAL AND QUALITATIVE LEADING EDGE.”

Helmut and Benjamin Rohde



Benefit from the tips and information presented on these pages when choosing your new kiln and enjoy your results – right from the start.



Energy

The creative process begins with the choice of the type of energy used in your firing processes. ROHDE kilns are suitable for electrical or gas operation.

Advantages of electrically operated kilns:

- Fully automated and precise control of the firing process using intuitive controllers
- Easy and reproducible control of the firing process using storable firing programs
- Runs automatically without the need for monitoring of the firing process

Requirements: 230V ("Schuko" connector) up to 60 litres kiln volume, high-voltage current for larger models

Advantages of gas-operated kilns:

- Allows firing techniques such as reduction or Raku firing
- Best possible energy efficiency for kiln volumes above 300 litres
- Know-how is important for manual control of the firing process

Requirements: propane, butane or natural gas supply

Firing temperature

Before buying a kiln, you usually know exactly what firing temperatures will be necessary for your applications. With the exception of some models, most of the ROHDE product range is suitable for maximum temperatures of 1320°C. This means you are on the safe side for almost any project.

To achieve sufficient power reserve for toploaders up to 60 litres, ROHDE recommends selection of the high-voltage variant for applications requiring more than 1200°C.

Kiln size

The kiln size is determined by the size of the ware to be fired and the firing rhythm. If you fire mainly different sizes or very small pieces, ROHDE recommends that you purchase two smaller kilns instead of just one large one. Large kilns only work economically if they are tightly loaded. However, large individual pieces require a bigger kiln. The somewhat higher initial costs for a customised construction may achieve break-even within a short period of time. When considering the details for interior dimensions, consider a buffer in space for unheated areas and heating elements.

Keep in mind the transport and movement of your kiln to its operating location and make appropriate arrangements. In addition, the kiln volume of many ROHDE Toploader models can be increased by fitting in an extension ring. This not only makes it significantly easier to transport your kiln, but also allows it to be adjusted to additional requirements later.

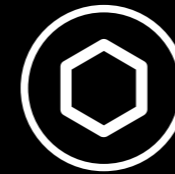

Design

The technical opportunities allow for endless design variations. Whether round, rectangular or square, whether you load from front, top or a kiln floor that is pulled out – there are no limits to design options. The choice depends on your individual conditions and requirements:

- Top loading: good overview of the firing chamber – choose a toploader
- Front loading: effective use of kiln height – choose a frontloader
- Loading from more than one side: optimal efficiency, safety and ergonomics – choose a hood kiln or the ELS Ergo Load System

The way the heating elements are mounted makes a difference in electrically operated kilns:

- Recessed into grooved bricks: heating elements mounted in protected position against damage
- Mounted on support rods: good heat radiation, heating elements can be easily replaced

The technically solid dimensioning of each heating element and the use of high-quality Kanthal wire are important requirements for highest performance and efficiency. When it comes to exact calculation, ROHDE considers a low surface load, a good gradient factor and the highest possible wire strength as decisive factors for durability and power reserve.

ROHDE recommends using heating elements mounted on support rods for regular applications at temperature ranges higher than 1280°C.

Accessories and equipment

Efficient accessories and additional equipment make the daily working routine easier. First consider available features and then choose according to your requirements:

- Controller: easy and intuitive to operate, detachable, safe over-temperature cut-out
- Safety: door safety switch, low external temperature, lockable kiln door
- Exhaust air: good air ventilation of the firing chamber using exhaust air and air supply slides or exhaust air socket
- Available special features: kiln floor heating, multiple-zone control, door hinge on left side instead of right, lid heating, exhaust air hood, castors, view port to monitor firing

ROHDE can always provide a simple and efficient solution for almost any special request.

Quality

The quality of a kiln is basically shown by such criteria as durability, firing results, functional safety as well as energy consumption and the necessity for spare parts. The design of ROHDE products is outstanding in all these aspects providing the highest product confidence. High-quality material and construction properties such as a V2A stainless steel jacket or a completely ventilated steel frame guarantee highest quality and corrosion protection. The top and walls are joined mortar-free and are not only attractive but allow natural thermal expansion of the kiln, preventing cracks and particles falling from the ceiling onto the ware. These are optimal prerequisites for a long service life, reliable functionality and first-class results.

Incidentally, all ROHDE kilns for ceramics and glass applications have a 3-year warranty!



WHICH KILN IS **SUITABLE**
FOR ME?

TOP FOR YOUR BEST POSSIBLE **RESULTS.**

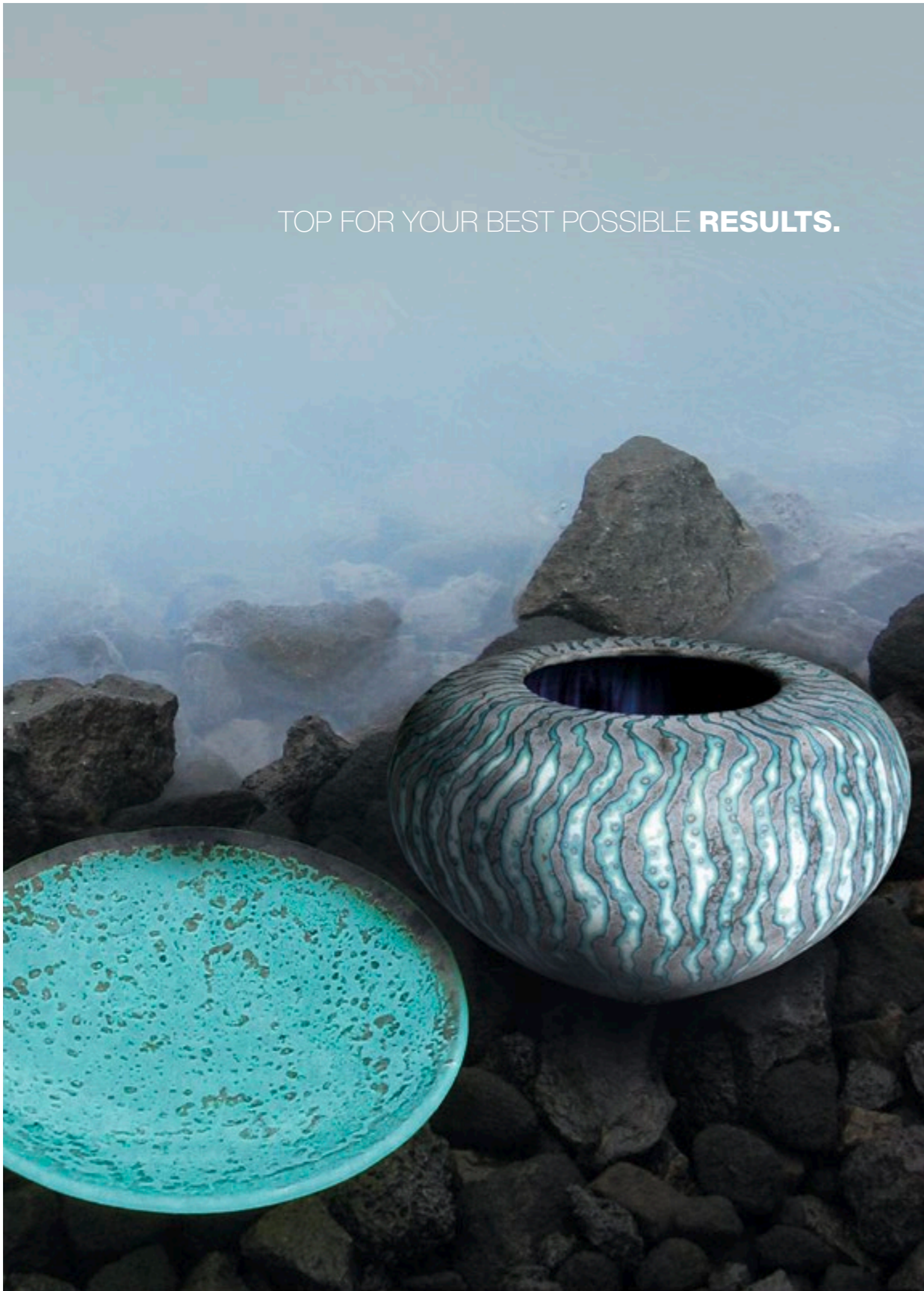

ROHDE TOPLOADERS



Toploaders Details

ROHDE Toploaders are high-quality kilns for everyday use in professional ceramic workshops. The different kiln series have been continually developed by ROHDE and today incorporate state-of-the-art technology and extreme durability.

Many ceramic workshops appreciate the flexibility and extendability of some models and use this feature to increase the economic efficiency of their firing capacities to obtain the best possible results.

Besides an extensive range of technical features and high-quality workmanship, ROHDE Toploaders offer particular technical features, such as:

Extendability

The kiln volume of some models from the ROHDE Toploader TE series can be increased by up to 50% by simply fitting in an additional heatable extension ring (ZWR).

Mount the ring, connect the kiln to the mains supply and continue working with 50% more firing capacity. ROHDE Toploaders are able to meet your increasing requirements at any time.

Reversible kiln stand

This construction developed specially by ROHDE offers significant advantages particularly when it comes to charging the kiln. After safe delivery, the construction allows you to adjust the toploader to an individual working height making loading and unloading of the firing chamber much easier on the back.

Disassembly

All models from the TE series can be disassembled easily. The individual parts can be transported to any operating location and can fit through a doorway of only 55 cm without problem.

Electronic solid-state relays

The power on all ROHDE Toploaders is controlled by electronic solid-state relays. These silent and low-wear high-performance components are operated without mechanical contacts. The solid-state relays are cooled by an external cooling element mounted outside the switch cabinet. This prevents additional heat from getting into the electric control device and guarantees consistent, trouble-free operation.



Solid lid hinge, pressure spring-supported opening mechanism for the lid



Fixing device for safe fastening of the kiln controller



Exhaust air socket to connect exhaust tube



Silent and low-wear stainless steel switch cabinet, solid-state relays with cooling element



Reversible kiln stand, handy and practical



High, low and flexible.



Practical to transport and practical to extend.



Toploaders Ecotop series

Efficient, safe and economical.

The future-oriented models from the Ecotop series are among the most recent developed kiln range of ROHDE. The Ecotop is currently one of the most economical kilns on the market and features a new and unique insulation concept that allows for very high energy efficiency.

The 3-layer insulation structure featuring a high-quality microporous 15 mm back insulation can be safely fired to stoneware temperatures using a regular 230 V "Schuko" plug connector (3.6 kW).

Special features of the Ecotop series:

- 3-layer insulation concept with 15 mm microporous insulating board
- Particularly high energy efficiency
- Reversible kiln stand, handy and practical
- Pressure spring-supported opening mechanism for the lid
- Power control effected by silent, low-wear solid-state relays with an external cooling element



Wall structure with additional microporous back insulation

Reversible kiln stand, handy and practical

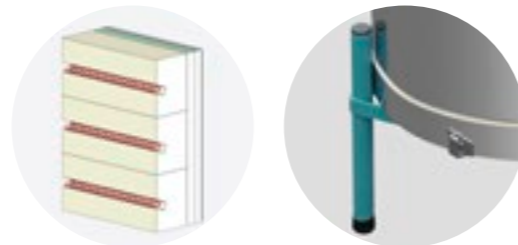

Electric Toploaders **ECOTOP** series to 1320°C

Model Volume	Tmax °C	Int. dimensions mm			Ext. dimensions mm			Output kW	Supply A	Connector Plug	Furniture batts w x d mm	Weight kg
		w	d	h	W	D	H					
Ecotop 20	1320	330	230		640	640	660	2,3	10,0	Schuko	ø 290	44
Ecotop 43 L	1320	400	340		700	730	770	2,9	13,0	Schuko	ø 350	58
Ecotop 50	1320	400	380		700	730	830	3,6	16,0	Schuko	ø 350	58
Ecotop 50 S	1320	400	380		700	730	830	4,5	6,5	CEE 16 A	ø 350	58
Ecotop 60 L	1200	400	450		700	730	900	2,9	13,0	Schuko	ø 350	60
Ecotop 60	1320	400	450		700	730	900	3,6	16,0	Schuko	ø 350	60
Ecotop 60 S	1320	400	450		700	730	900	5,0	7,5	CEE 16 A	ø 350	60

Special voltage electric supply for all EU networks available on request

Toploaders TE-MCC+ series

The solid ROHDE Toploaders from the MCC+ series can be used for a variety of applications ranging from glass processing at 800°C to manufacture of stoneware at 1280°C. Toploaders from this series are particularly suitable for use in public institutions such as schools and kindergartens, as well as for both artists and hobbyists. The wide temperature range allows maximum flexibility when it comes to artistic craftsmanship in the field of ceramics and glass.

Special features of the TE-MCC+ series

Models TE 75, TE 100, TE 130 and TE 200 MCC+ can be fitted easily with a heatable lid required for glass processing. The heating elements are mounted on support rods that prevent particles falling from the kiln lid onto the ware.

Extendability

The kiln volume of four models from the ROHDE Toploader TE series can be increased by 50% by simply fitting in a heatable additional extension ring (ZWR):

- TE 75 MCC+ to 110 litres volume
- TE 100 MCC+ to 150 litres volume
- TE 130 MCC+ to 190 litres volume
- TE 200 MCC+ to 300 litres volume

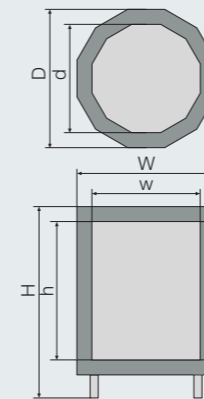

2-layer wall structure
TE-MCC+ series

Optional lid heating, heating elements mounted on high-quality ceramic support rods



Electric Toploaders **TE-MCC+** series to 1320°C

Model Volume	Tmax °C	Int. dimensions mm			Ext. dimensions mm			Output kW	Supply A	Connector Plug	Furniture batts w x d mm	Weight kg
		w	d	h	W	D	H					
TE 75 MCC+	1320	ø 470	460		760	730	780	6,0	13	CEE 16 A	410	82
ZWR 75 MCC+		ø 470	230		760	730	230	3,0	-	-	-	23
TE 110 MCC+	1320	ø 470	680		760	810	1010	9,0	13	CEE 16 A	410	105
TE 100 MCC+	1320	ø 520	460		800	800	780	7,0	15	CEE 16 A	470	89
ZWR 100 MCC+		ø 520	230		800	800	230	3,5	-	-	-	20
TE 150 MCC+	1320	ø 520	680		800	870	1000	10,5	15	CEE 16 A	470	109
TE 130 MCC+	1320	ø 590	460		860	880	780	7,3	16	CEE 16 A	540	106
ZWR 130 MCC+		ø 590	230		860	880	230	3,7	-	-	-	25
TE 190 MCC+	1320	ø 590	680		860	940	1010	11,0	16	CEE 16 A	540	125
TE 200 MCC+	1320	ø 740	460		1020	1010	780	9,2	20	CEE 32 A	Cut to size	130
ZWR 200 MCC+		ø 740	230		1020	1010	230	4,6	-	-	-	32
TE 300 MCC+	1320	ø 740	680		1030	1030	1010	13,8	20	CEE 32 A	Cut to size	70

ZWR = Extension ring to increase volume

Special voltage electric supply for all EU networks available on request

Toploaders TE-S series

ROHDE Toploaders from the TE-S series are high-quality kilns for everyday use in professional ceramic workshops. The kilns in this series have been continually developed by ROHDE over the last three decades. Toploaders from the TE-S series guarantee state-of-the-art technology and are characterised by outstanding durability.

Many ceramic workshops appreciate the flexibility and extendability of some models and use this feature to increase the economic efficiency of their firing capacities to obtain the best possible results. Besides an extensive range of technical features and high-quality workmanship, ROHDE Toploaders from the TE-S series offer particular technical features, such as:

Extendability

The kiln volume of four models from the ROHDE Toploader TE-S series can be increased up to 50% by simply fitting in a heatable additional extension ring (ZWR).

- TE 80 S to 100 litres volume
- TE 95 S to 145 litres volume
- TE 130 S to 200 litres volume
- TE 165 S to 250 litres volume

Floor heating

Models of the TE-S series from TE 95 S upwards are equipped with a standard heatable kiln floor. The additional heating provides an even temperature distribution in particular in the lower and middle temperature ranges.

Standard heatable floor from TE 95 S upwards

Reversible kiln stand, handy and practical

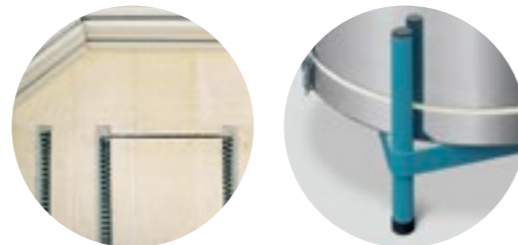

Electric Toploaders TE-S series to 1320°C

Model	Volume	Tmax °C	Int. dimensions mm			Ext. dimensions mm			Output kW	Supply A	Connector Plug	Furniture batts w x d mm	Weight kg
			w	d	h	W	D	H					
TE 80 S		1320	ø 450	460	790	800	780	6,0	13	CEE 16 A	410	99	
ZWR 80 S			ø 450	150	790	800	150	3,0	-	-	-	20	
TE 100 S		1320	ø 450	610	790	850	930	9,0	13	CEE 16 A	410	117	
TE 95 S		1320	ø 520	460	850	860	790	7,3	16	CEE 16 A	470	113	
ZWR 95 S			ø 520	230	850	860	230	3,7	-	-	-	29	
TE 145 S		1320	ø 520	680	850	910	1020	11,0	16	CEE 16 A	470	142	
TE 130 S		1320	ø 610	460	930	930	790	8,8	19	CEE 32 A	540	130	
ZWR 130 S			ø 610	230	930	930	230	4,4	-	-	-	33	
TE 200 S		1320	ø 610	680	930	990	1020	13,2	19	CEE 32 A	540	166	
TE 165 S		1320	730	630	460	1050	930	790	10,0	22	CEE 32 A	Cut to size	144
TWR 165 S			730	630	230	1050	930	230	5,0	-	-	-	36
TE 250 S		1320	730	630	680	1050	980	1020	15,0	22	CEE 32 A	Cut to size	180
TE 300 S		1320	840	640	680	1060	950	1020	15,0	22	CEE 32 A	Cut to size	204

ZWR = Extension ring to increase volume

Special voltage electric supply for all EU networks available on request

Toploaders Quattro TE-Q series

The Quattro TE-Q series comprises two different series: models TE-QN and TE-QS in square design with 4-side heating and elements recessed into grooved bricks, and models TE 70 QT/QTS and 110 QT with 4-side heating and elements mounted on support rods.

Both designs are equipped with a high-quality 2-layer insulation structure that is fitted precisely into a very sturdy frame construction. The high-quality, two-colour industrial lacquer used on the frame turns the Quattro series into attractive ROHDE Toploaders. The in-frame ventilated lid and the use of galvanized steel sheet in the kiln casing provide effective protection against corrosion. Another feature of this series is the carefully manufactured kiln lid, as the round toploader it is provided with a pressure spring that allows easy opening of the lid.

Rectangular toploaders BT series

The BT series combines 5-side heating in a robust frontloader construction with all the advantages of a toploader. The high-quality insulation structure and the even temperature distribution make the rectangular toploader suitable for workshop applications where as many ceramic products as possible must be placed and processed in one firing process. During kiln charging, the rectangular toploader offers an excellent overview of the ware to obtain the best possible results.

2-layer wall structure, heating elements mounted in protected position recessed into grooved bricks

Easy lid opening and closing using gas pressure springs



Electric Toploaders TE-Q and BT series to 1320°C

Model	Volume	Tmax °C	Int. dimensions mm			Ext. dimensions mm			Output kW	Supply A	Connector Plug	Furniture batts w x d mm	Weight kg
			w	d	h	W	D	H					
TE 10 Q		1320	180	230	230	390	600	560	1,8	- 8	Schuko	200 x 150	30
TE 35 Q		1320	380	380	230	630	780	570	3,6	- 16	Schuko	330 x 330	81
TE 50 QN		1320	380	380	340	630	780	680	3,6	- 16	Schuko	330 x 330	100
TE 50 QS		1320	380	380	340	630	780	680	5,0	11 22	CEE 16 A	330 x 330	100
TE 70 QT		1250	410	410	420	730	870	760	3,6	- 16	Schuko	360 x 360	145
TE 70 QT-S		1320	410	410	420	730	870	760	6,0	13 26	CEE 16 A	360 x 360	150
TE 110 QT		1320	450	450	530	800	920	870	9,0	13 40	CEE 16 A	400 x 400	250
BT 300		1320	920	570	610	1360	970	1070	15,0	25 -	CEE 32 A	500 x 400	400
BT 500		1320	1150	650	690	1620	1050	1150	24,0	34 -	CEE 63 A	600 x 500	535

Special voltage electric supply for all EU networks available on request

Hood Kilns HE series

ROHDE Hood Kilns from the HE series are the consequent technical development of the Toploader TE-S series. As there are limits to top loading, ROHDE Hood Kilns are a practical and efficient alternative to the larger models from the Toploader TE-S series.

These models do not require top or front loading, but the entire kiln must be positioned easily and without effort like a hood over the ware to be fired. This allows individual large pieces to be positioned freely on the kiln floor.

This construction makes charging the kiln floor with ceramics remarkably easy on the back. The proven, highly flexible ROHDE ring system allows for almost every concept, such as individual pieces with diameters up to 1.5 m or kilns with (almost) any internal heights.

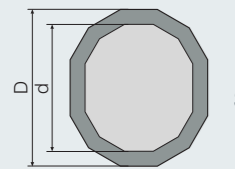

Smooth and easy rope winch for safe and effortless lifting of the kiln hood

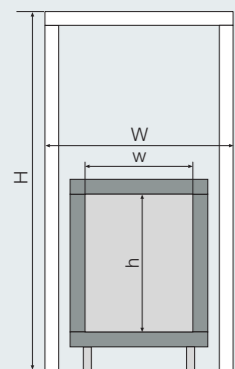

Easy moving of the kiln floor using a pallet truck makes it accessible for charging

Kiln floor on optional rails allows safe charging of large workpieces

An optional hydraulic system allows the hood to be easily moved



Electric Hood Kilns **HE** series to 1320°C

Model	Tmax °C	Int. dimensions mm			Ext. dimensions mm			Output kW	Supply A	Connector Plug	Furniture batts w x d mm	Weight kg
		w	d	h	W	D	H					
HE 200	1320	610	680	1500	850	2210	13	19	CEE 32 A	540	235	
HE 260	1320	610	910	1500	850	2400	18	25	CEE 32 A	540	270	
HE 250	1320	640	730	680	1500	1250	2250	15	22	CEE 32 A	Cut to size	270
HE 330	1320	640	730	910	1500	1250	2480	20	30	CEE 32 A	Cut to size	310
HE 300	1320	640	840	680	1500	1080	1800	17	24	CEE 32 A	Cut to size	300
HE 400	1320	640	840	910	1500	1080	2440	22	32	CEE 32 A	Cut to size	340

Special voltage electric supply for all EU networks available on request

ROHDE Electric Toploaders **Overview**

Features	Ecotop	TE-MCC+	TE-S	HE	TE-Q N/S	TE-QT	BT
End temperature	1320°C*	1320°C	1320°C	1320°C	1320°C	1320°C*	1320°C
All-around heating	•	•	•	•	•	•	•
Floor heating	-	-	•*	•	-	-	•
Lid heating	-	•	-	-	-	-	-
Electronic solid-state relays	•	•	•	•	•	•	•
Heating elements in grooved bricks	•	•	•	•	•	-	•
Heating elements on support rods	-	-	-	-	-	•	-
Reversible kiln stand, handy and practical	•	•	•	-	-	-	-
Exhaust air socket	•	•	•	•	•	•	•
View port	•	•	•	•	•	•	•
Support for controller	•	•	•	-	-	-	-
Air supply slide	•	•	•	•	-	-	-
Can be disassembled for transport	•	•	•	•	-	-	•
Can be extended	-	•	•	-	-	-	-
3-years warranty	•	•	•	•	•	•	•
CE conformity marking	•	•	•	•	•	•	•

• Standard equipment • Optional - Not available * Not available for all models

TREASURY OF
YOUR **SKILLS.**

ROHDE FRONTLOADERS





Advantages in detail



Corrosion protection and low external temperature due to in-frame ventilation



Silent, low-wear solid-state relay with an external cooling element



Connector for controller and micro-fuse easily accessible



New exhaust air flap handle with larger exhaust air opening



Security switch mounted in protected position



Adjustable door catch, lockable



Air supply slide operated from front, improved air supply handling



Compact, easy-to-open assembly of electrical components at back of kiln

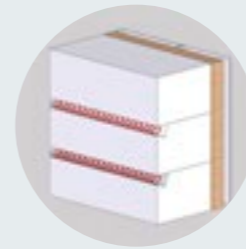

2-layer wall structure for KE-B series

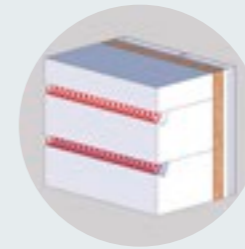

3-layer wall structure for KE-N / ELS-N series

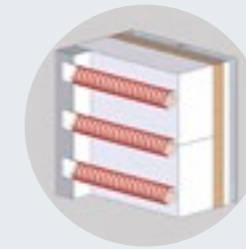

3-layer wall structure for KE-S / S+ / ELS-S series



3-layer wall structure for KE-SH series



Thermocouple mounted in protected position



Heating elements mounted on support rods, KE-S / S+ / SH / ELS-S series



"System ROHDE" R-SiC ceiling support prevents cracks and particles falling from the ceiling onto the ware



Adjustable door hinge, easy dismantling of door for transport

Electric Frontloaders



Frontloaders KE-B series

Kiln models from the KE-B series have been developed from the successful and proven KE-L series.

The KE-B series comprises Frontloaders with 3-side heating and a kiln volume of 35 to 210 litres. You can choose between the compact tabletop models KE 35 B and KE 65 B as well as four floor models KE 105 B to KE 210 B.

Frontloaders from the KE-B series are particularly suitable for use in public institutions, such as schools, kindergartens and therapy centres. These electrically operated kilns offer best possible performance and a variety of options for hobby and decorative applications or casting techniques. The advantages of a frontloader can be effectively used, ensuring a balanced price-to-performance ratio.

The unique technical features of ROHDE Frontloaders have been incorporated into the KE-B series. The entire in-frame ventilated steel construction prevents corrosion and at the same time reduces external temperatures. The proven "System ROHDE" ceiling construction has also been incorporated into the KE-B series.

Heat is radiated from heating elements recessed into developed grooved bricks in the two side walls and the floor. Solid calculation of heating elements with sufficient power reserve results in an efficient, even distribution of heat throughout the firing chamber to obtain the best possible results.

ROHDE Frontloaders from the KE-B series can be extended with different accessories such as an air supply slide, a loading frame or an exhaust air hood.

Special features of the KE-B series:

- 3-side heating resulting in even heat distribution
- Heating elements recessed in protected position into new grooved bricks
- In-frame ventilation for low external temperatures and corrosion protection
- Enhanced 3-layer insulation structure of tabletop models KE 35 B and KE 65 B
- Enhanced 2-layer insulation structure of floor models from KE 105 B upwards
- "System ROHDE" R-SiC ceiling support prevents cracks and particles falling from the ceiling onto the ware
- Optional kiln stand for tabletop models, floor models mounted on stable and fixed base



KE 35 B



KE 210 B

All-around in-frame ventilated casing reduces external temperatures and prevents corrosion

"System ROHDE" R-SiC ceiling support prevents cracks and particles falling from the ceiling onto the ware

Heating elements recessed in protected position into new grooved bricks

Security switch mounted in protected position



Photo Patricia Schichtl

Electric Frontloaders **KE-B** series to 1280°C

Model	Tmax	Int. dimensions mm	Ext. dimensions mm	Output	Supply	Connector	Furniture batts	Weight
Volume	°C	w d h	W D H	kW	A	Plug	w x d mm	kg
KE 35 B	1280	340 340 340	600 680 750	3,6	16	Schuko	300 x 300	100
KE 65 B eco	1200	380 380 450	620 700 800	3,6	16	Schuko	330 x 350	120
KE 65 B	1280	380 380 450	620 700 800	5,5	12	CEE 16 A	330 x 350	120
KE 105 B	1280	450 410 570	760 910 1600	7,0	16	CEE 16 A	370 x 340	260
KE 130 B	1280	450 450 640	760 960 1600	8,0	16	CEE 16 A	400 x 380	330
KE 170 B	1280	450 530 720	760 1030 1600	9,0	16	CEE 16 A	440 x 400	360
KE 210 B	1280	450 640 720	760 1100 1600	11,0	16	CEE 16 A	560 x 400	390

Special voltage electric supply for all EU networks available on request

Frontloaders KE-N series

ROHDE Frontloaders from the KE-N series comprise six models with kiln volumes between 100 and 480 litres. The heating elements are recessed into grooved firebricks on all five wall sides.

The KE-N series has been designed for use in workshops and schools. The heating elements in this series have been recessed into grooved bricks. This results in a variety of advantages. The heating elements are protected while the kiln is being charged, power output is constant and heat is evenly distributed throughout the firing chamber, providing the best possible results.

Special features of the KE-N series:

- 5-side heating resulting in even heat distribution
- Heating elements recessed into grooved bricks
- Stainless steel in-frame ventilation resulting in low external temperatures and corrosion protection
- 3-layer insulation structure
- "System ROHDE" R-SiC ceiling support prevents cracks and particles falling from the ceiling onto the ware



KE 200 N

Heating elements recessed in protected position into grooved bricks

Adjustable door hinge, easy dismantling of door for transport

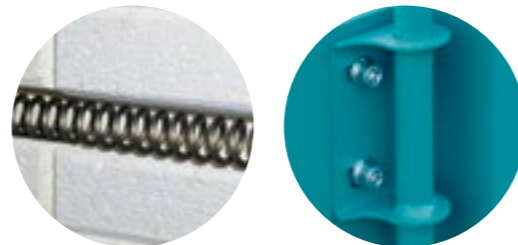

Frontloaders KE-S series

ROHDE Frontloaders from the KE-S series comprise nine models with kiln volumes between 100 and 1000 litres. The heating elements are mounted on support rods. 5-side heating provides even temperature distribution throughout every performance range.

The KE-S series was designed for daily use over many years in professional workshops at firing temperatures up to 1320°C. However, they are also suitable for everyday applications in schools, providing the best possible results.

Special features of the KE-S series:

- 5-side heating resulting in even heat distribution
- Heating elements mounted on support rods
- Stainless steel in-frame ventilation resulting in low external temperatures and corrosion protection
- 3-layer insulation structure
- "System ROHDE" R-SiC ceiling support prevents cracks and particles falling from the ceiling onto the ware



KE 200 S

Heating elements mounted on support rods

Door handle with new design and handy stainless steel pipe

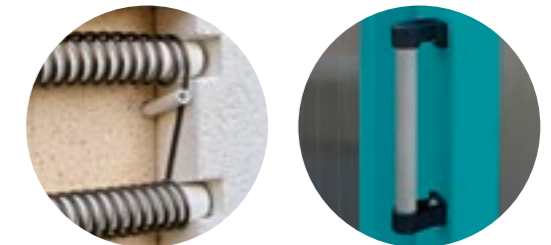

Electric Frontloaders **KE-N** series to 1300°C

Model	Tmax	Int. dimensions mm			Ext. dimensions mm			Output	Supply	Connector	Furniture batts	Weight
Volume	°C	w	d	h	W	D	H	kW	A	Plug	w x d mm	kg
KE 100 N	1300	410	480	530	750	1050	1700	6,6	10	CEE 16 A	400 x 370	323
KE 150 N	1300	460	480	680	800	1050	1780	9,0	13	CEE 16 A	440 x 400	375
KE 200 N	1300	460	640	680	800	1210	1780	11,0	16	CEE 16 A	600 x 400	415
KE 250 N	1300	530	640	760	870	1210	1800	13,7	20	CEE 32 A	600 x 500	471
KE 330 N	1300	590	720	790	920	1280	1800	16,5	25	CEE 32 A	550 x 340 (2)	531
KE 480 N	1300	640	770	980	980	1340	1830	22,0	32	CEE 32 A	600 x 360 (2)	641

Special voltage electric supply for all EU networks available on request

Electric Frontloaders **KE-S** series to 1320°C

Model	Tmax	Int. dimensions mm			Ext. dimensions mm			Output	Supply	Connector	Furniture batts	Weight
Volume	°C	w	d	h	W	D	H	kW	A	Plug	w x d mm	kg
KE 100 S	1320	410	470	540	750	1040	1700	8,0	12	CEE 16 A	400 x 370	324
KE 150 S	1320	460	470	690	800	1050	1780	10,5	16	CEE 16 A	420 x 400	363
KE 200 S	1320	460	630	680	800	1210	1770	13,2	20	CEE 32 A	560 x 400	416
KE 250 S	1320	540	630	760	870	1200	1810	16,5	25	CEE 32 A	600 x 480	470
KE 330 S	1320	590	720	800	930	1280	1800	22,0	32	CEE 32 A	600 x 500	529
KE 480 S	1320	640	770	1020	980	1340	1830	32,0	47	CEE 63 A	580 x 350 (2)	630
KE 600 S	1320	720	870	1020	1460	1430	2040	40,0	59	CEE 63 A	370 x 335 (4)	1020
KE 750 S	1320	720	1100	1030	1570	1690	2010	50,0	73	–	475 x 335 (4)	1122
KE 1000 S	1320	920	1070	1140	1660	1610	2040	70,0	100	–	480 x 435 (4)	1250

Special voltage electric supply for all EU networks available on request

Frontloaders KE-S+ series

ROHDE Frontloaders from the KE-S+ series comprise six models with kiln volumes between 100 and 480 litres. The heating elements are mounted on support rods. 5-side heating provides even temperature distribution throughout every performance range.

The KE-S+ series was designed for demanding applications and use over many years in professional workshops. The 3-layer microporous insulation structure allows for maximum firing temperatures of 1350°C providing the best possible results.

Special features of the KE-S+ series:

- 5-side heating resulting in even heat distribution
- Heating elements mounted on support rods
- Stainless steel in-frame ventilation resulting in low external temperatures and corrosion protection
- 3-layer insulation structure
- "System ROHDE" R-SiC ceiling support prevents cracks and particles falling from the ceiling onto the ware



KE 200 S+

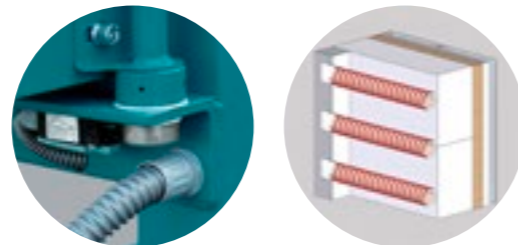

Security switch mounted in protected position

3-layer wall structure KE-S+ series

Frontloaders KE-SH series

ROHDE Frontloaders from the KE-SH series comprise six models with kiln volumes between 100 and 480 litres. The heating elements are mounted on support rods. 5-side heating provides even temperature distribution throughout every performance range.

The KE-SH series was designed for demanding applications and use over many years in professional workshops. The highly durable heating elements and the specific 3-layer wall structure allow for maximum temperatures of 1400°C and obtaining the best possible results.

Special features of the KE-SH series:

- 5-side heating resulting in even heat distribution
- Heating elements mounted on support rods
- Stainless steel in-frame ventilation resulting in low external temperatures and corrosion protection
- 3-layer insulation structure
- "System ROHDE" R-SiC ceiling support prevents cracks and particles falling from the ceiling onto the ware



KE 200 SH

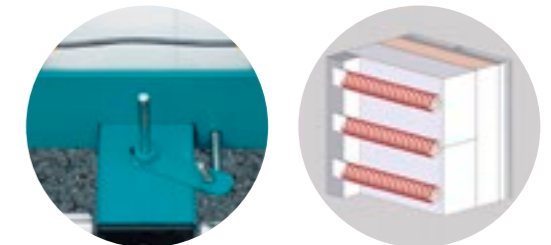

Air supply slide operated from front, improved air supply handling

3-layer wall structure KE-SH series

Electric Frontloaders **KE-S+** series to 1350°C

Model Volume	Tmax °C	Int. dimensions mm			Ext. dimensions mm			Output kW	Supply A	Connector Plug	Furniture batts w x d mm	Weight kg
		w	d	h	W	D	H					
KE 100 S+	1350	410	470	540	750	1040	1700	8,0	12	CEE 16 A	400 x 370	340
KE 150 S+	1350	460	470	690	800	1050	1780	10,5	16	CEE 16 A	420 x 400	385
KE 200 S+	1350	460	630	680	800	1210	1770	13,2	20	CEE 32 A	560 x 400	434
KE 250 S+	1350	540	630	760	870	1200	1810	16,5	25	CEE 32 A	600 x 480	523
KE 330 S+	1350	590	720	800	930	1280	1800	22,0	32	CEE 32 A	600 x 500	554
KE 480 S+	1350	640	770	1020	980	1340	1830	32,0	47	CEE 63 A	580 x 350 (2)	693

Special voltage electric supply for all EU networks available on request

Electric Frontloaders **KE-SH** series to 1400°C

Model Volume	Tmax °C	Int. dimensions mm			Ext. dimensions mm			Output kW	Supply A	Connector Plug	Furniture batts w x d mm	Weight kg
		w	d	h	W	D	H					
KE 100 SH	1400	410	480	530	810	1120	1700	10,5	16	CEE 16 A	400 x 370	403
KE 150 SH	1400	460	475	680	860	1130	1790	15,0	22	CEE 32 A	420 x 400	492
KE 200 SH	1400	460	640	680	860	1280	1790	18,0	26	CEE 32 A	560 x 400	558
KE 250 SH	1400	520	630	770	1020	1270	1840	24,0	35	CEE 63 A	560 x 480	625
KE 330 SH	1400	580	710	800	1080	1350	1840	32,0	47	CEE 63 A	600 x 500	690
KE 480 SH	1400	630	770	995	1130	1410	1860	40,0	58	CEE 63 A	580 x 350 (2)	800

Special voltage electric supply for all EU networks available on request

ROHDE ELS Ergo Load System

The ROHDE kiln concept ELS Ergo Load System is a completely new and unique kiln series that makes the daily charging routine significantly easier, safer and kinder on the back. The innovative ROHDE-patented kiln concept has been further developed and incorporated into the ELS-N and ELS-S series.

The smooth running mechanism of this kiln type allows the kiln floor to be pulled out completely. The kiln floor can be pulled out effortlessly using the door that opens to 180° and allows charging on three sides. This makes it not only faster, safer and more efficient to load the kiln but also improves the setting density of the kiln by 20% thus saving time and energy and reducing firing costs.

Even heavy components such as furniture batts can be positioned ergonomically without problem in the ELS series. The improved ROHDE Ergo Load System makes your daily charging routine child's play and lifts your working routine to a completely new level.

Easy on the back

Robust rails and ball bearing rollers allow the drawer floor to be pulled out easily and smoothly enabling convenient loading from three sides. Comfortable, ergonomic and safe.

High-quality

The entire steel construction is equipped with an in-frame ventilation made of stainless steel sheets. The insulation comprises three layers. We use only high-quality, reduction-resistant insulating firebricks in the firing chamber. The kiln floor is fitted with a conical sealing cord providing optimum sealing and preventing incoming draughts.

Safe

The door safety switch and the over-temperature protection meet the highest ROHDE requirements for safety and guarantee smooth kiln operation. All ROHDE kilns for ceramics and glass applications have a 3-year warranty!

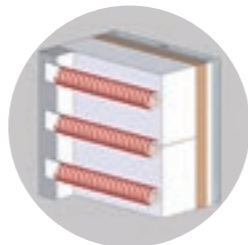

"System ROHDE" R-SiC ceiling support prevents cracks and particles falling from the ceiling onto the ware

Corrosion protection and low external temperatures due to stainless steel in-frame ventilation

Durable heating elements with sufficient power reserve allow efficient and even distribution of heat

ELS Ergo Load System Patented drawer system that is easy on the back; drawer floor can be operated electrically as an option

Energy-saving and efficient: even temperature distribution inside the kiln and high-quality insulation for low external temperatures



The ROHDE **ELS Ergo Load System**.

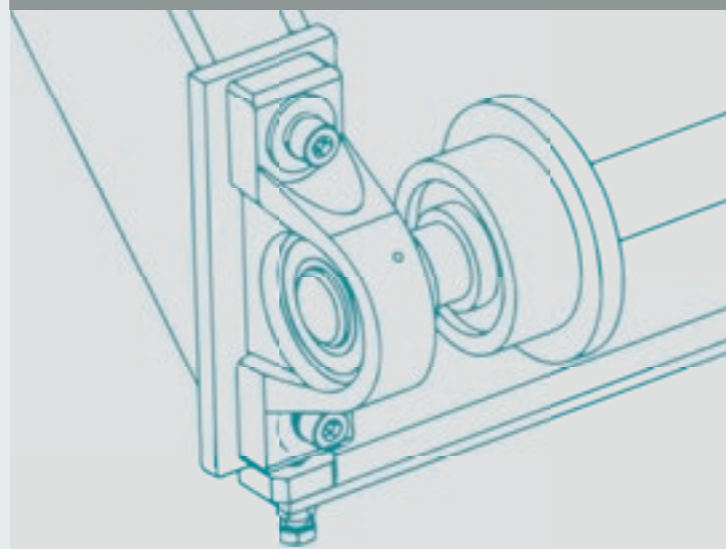

Option: **Drawer floor can be moved out electrically**.



Frontloaders ELS Ergo Load System ELS-N series

ROHDE Frontloaders with Ergo Load System from the ELS-N series comprise two models with kiln volumes between 150 and 200 litres. The heating elements are recessed into new grooved firebricks on all five wall sides. The new, robust groove geometry provides the best possible protection for heating elements when the kiln is being charged. Constant power output ensures that heat is evenly distributed throughout the firing chamber to provide the best possible results.

The ELS-N series has been designed for use in workshops and schools. A 16-Ampere power connection allows kiln operation using a standard high-voltage socket (CEE 16 A). The high-quality 3-layer insulation structure allows for maximum firing temperatures of 1300°C.

Special features of the ELS-N series:

- 5-side heating resulting in even heat distribution
- Heating elements recessed in protected position into new grooved bricks
- Stainless steel in-frame ventilation resulting in low external temperatures and corrosion protection
- 3-layer insulation structure
- "System ROHDE" R-SiC ceiling support prevents cracks and particles falling from the ceiling onto the ware



ELS 200 N

Heating elements recessed in protected position into grooved bricks

Optional accessory: exhaust air hood

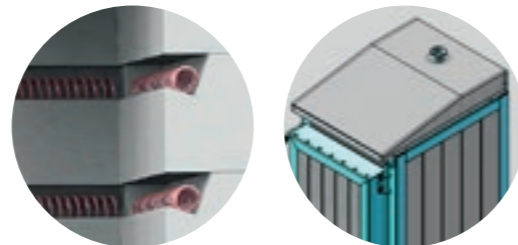

Electric Frontloaders **ELS-N** series to 1300°C

Model Volume	Tmax °C	Int. dimensions mm			Ext. dimensions mm			Output kW	Supply A	Connector Plug	Furniture batts w x d mm	Weight kg
		w	d	h	W	D	H					
ELS 150 N	1300	460	460	680	800	1080	1730	9,0	13	CEE 16 A	420 x 400	450
ELS 200 N	1300	460	620	680	800	1240	1730	11,0	16	CEE 16 A	560 x 400	510

Special voltage electric supply for all EU networks available on request

Frontloaders ELS series Ergo Load System ELS-S

ROHDE Frontloaders with Ergo Load System from the ELS-S series comprise six models with kiln volumes between 150 and 1000 litres. The heating elements are mounted on support rods. 5-side heating provides even temperature distribution in each performance range.

Frontloaders from the ELS-S series were designed for daily use over many years in professional workshops at firing temperatures up to 1320°C. In addition, they meet highest requirements for everyday applications in schools.

Special features of the ELS-S series:

- 5-side heating, resulting in even heat distribution
- Heating elements mounted on support rods
- Stainless steel in-frame ventilation resulting in low external temperatures and corrosion protection
- 3-layer insulation structure
- "System ROHDE" R-SiC ceiling support prevents cracks and particles falling from the ceiling onto the ware



ELS 200 S

Heating elements mounted on support rods

Easy charging on three sides when the kiln floor is pulled out



Electric Frontloaders **ELS-S** series to 1320°C

Model Volume	Tmax °C	Int. dimensions mm			Ext. dimensions mm			Output kW	Supply A	Connector Plug	Furniture batts w x d mm	Weight kg
		w	d	h	W	D	H					
ELS 150 S	1320	460	460	680	800	1080	1730	10,5	16	CEE 16 A	420 x 400	460
ELS 200 S	1320	460	620	680	800	1250	1670	13,2	20	CEE 32 A	560 x 400	550
ELS 330 S	1320	590	720	800	930	1310	1840	22,0	32	CEE 32 A	600 x 500	690
ELS 480 S	1320	640	770	995	1060	1420	1970	32,0	47	CEE 63 A	580 x 350 (2)	800
ELS 750 S	1320	720	1100	1030	1510	1730	1970	50,0	73	-	480 x 330 (4)	1350
ELS 1000 S	1320	920	1060	1145	1670	1730	2100	70,0	100	-	470 x 435 (4)	1500

Special voltage electric supply for all EU networks available on request

ROHDE Exhaust Air Hoods for Electric Frontloaders KE and ELS

The robust stainless steel exhaust air hoods cover the entire ceiling area of the frontloader absorbing exhaust air from the kiln. The ROHDE in-frame ventilated side walls direct the heat produced inside the kiln into the ceiling area. The exhaust air hood then absorbs and discharges it through a connected tube.

Exhaust air hoods can be connected to other pipes using a standardised socket. This should be done by a company specialising in ventilation and chimney systems.

Construction properties are perfectly matched to ROHDE Frontloaders allowing optimum removal of exhaust air, e.g. for Paperclay applications.

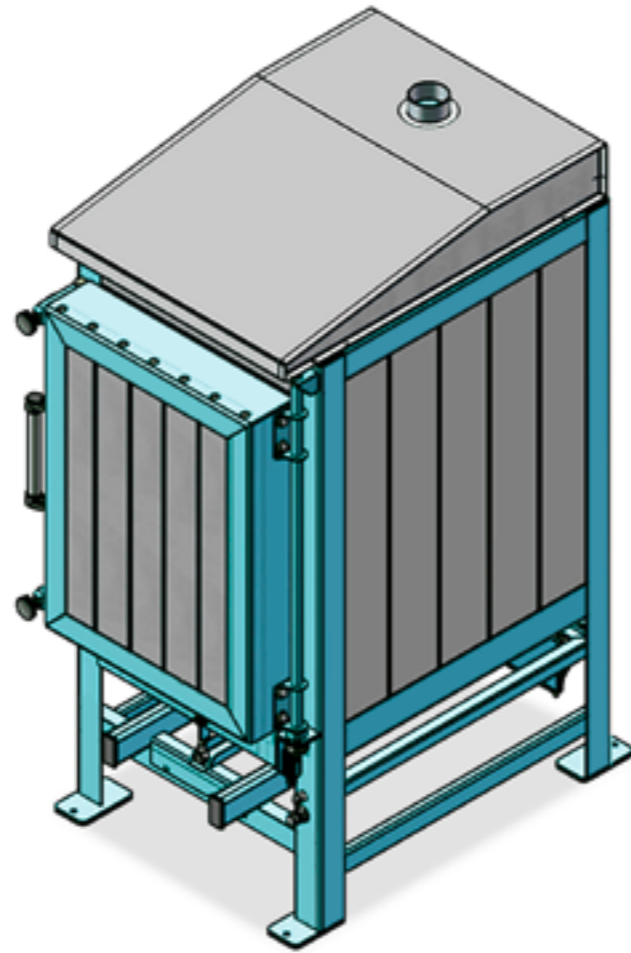

Optional accessories for Electric Frontloaders



Exhaust air flap handle, motor-driven



Air supply slide, motor-driven



Powerful cooling system



Door opening to the left

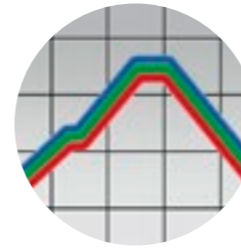

Multiple-zone control for best reproducibility and good temperature distribution



View port for monitoring of Seger cones



Drying rack for top of kiln



Forklift loading frame

ROHDE Electric Frontloaders Overview

Features	KE-B	KE-N	KE-S/S+/SH	ELS-N/S
Corrosion protection and low external temperature due to in-frame ventilation	•	•	•	•
In-frame ventilation using stainless steel sheets on both side walls and door	-	•	•	•
Ceiling sheet: punched metal sheet prevents accumulation of heat and moisture	•	•	•	•
5-side all-around heating resulting in even heat distribution	-	•	•	•
Kanthal A1 heating elements, mounted in protected position against displacement	•	•	•	•
Floor heating elements covered and protected by SiC batts	◦	•	•	•
Patented "System ROHDE" R-SiC ceiling support *	•	•	•	•
Thermocouple mounted in protected position	•	•	•	•
Stainless steel door frame	•	•	•	•
Door opens easily to approx. 180°, elastic door sealing	•	•	•	•
Exhaust air socket ø 80 mm to connect exhaust tube	◦	•	•	•
Easy-to-operate Exhaust air opening with flap handle	◦	•	•	•
Large, practical door handle	•	•	•	•
Adjustable door catch, lockable *	◦	•	•	•
Air supply slide enabling control of cooling air, operated from front	•	•	•	•
Legs detachable and easy mounting	-	•	•	-
Safety and control contactors according to VDE standards	•	•	•	•
Automatic kiln control	•	•	•	•
Silent, low-wear solid-state relay	•	•	•	•
Swivel-mounted support for controller	◦	•	•	•
Door opening to the left (controller right)	◦	◦	◦	◦
End temperature 1350°C or 1400°C	•	-	◦	-
View port in door to monitor firing	◦	◦	◦	◦
Air supply and exhaust air control ** ***	-	◦	◦	◦
Cooling system with ventilation ***	◦	-	◦	◦
Flexible exhaust air hose	◦	◦	◦	◦
Exhaust air hood	◦	◦	◦	◦
Drying rack for top of kiln *	◦	◦	◦	◦
Forklift loading frame *	-	◦	◦	-
Seal of approval for quality control	•	•	•	•
CE conformity marking	•	•	•	•
Maintenance-free, 3-year warranty (not on parts subject to wear)	•	•	•	•

• Standard equipment ◦ Optional - Not available

* Not available for KE 35 / 65 W ** Optional only in connection with controller TC 504 / 507 *** Not available for KE / ELS 200 / 330 S

ROHDE – FIRMLY SET IN QUALITY.

ROHDE

ROHDE GAS AND RAKU

A BURNING PASSION FOR THE BEST POSSIBLE **RESULTS.**



Gas Toploaders TG series

Gas-fired ROHDE Toploaders from the TG series combine high-level technology with economic efficiency. ROHDE gas technology is easy and safe to handle. It can be controlled individually and has very low energy consumption providing at the same time the best possible results.

Downdraft flame control technology ensures even temperature distribution. The extremely silent high-performance intermediate pressure burners were developed specially for gas-fired ROHDE Toploaders. They ensure an optimal temperature rise even in the high range and allow stable atmospheric control during firing. Reduction control is carried out manually using a flue slide. All models from the TG series are equipped with view ports to allow monitoring of the firing process using Seger cones. The gas fittings including safety technology are pre-installed for connection to gas bottles or gas lines according to DVGW (DVGW German Technical and Scientific Association for Gas and Water). A thermocouple with temperature meter is also supplied with the kiln.

You can choose the ROHDE Servo Jet equipment for firing a Toploader from the TG series with natural gas.

Special features of the TG series:

- Downdraft flame control technology
- Ring system, can be disassembled for transport and movement
- Pressure spring-supported opening mechanism for the lid
- Burner systems for propane, butane and natural gas

Special equipment:

- Oxygen probe for atmospheric measurement
- CO alarm and monitoring device
- ROHDE Servo Jet equipment for working with natural gas
- Stainless steel hood
- Castors, stable and robust



TG 80



Gas Toploaders **TG** series to 1320°C

Model	Tmax	Int. dimensions mm			Ext. dimensions mm			Output	Burners	Furniture batts	Weight
		Volume	°C	w	d	h	W				
TG 80	1320	520	500	450	870	800	760	20	1	420	120
TG 170	1320	650	640	530	1020	930	830	40	2	550	150
TG 220	1320	650	640	690	1020	930	990	40	2	550	180
TG 270	1320	770	640	690	1130	930	990	40	2	Special	200

Gas Frontloaders KG series

Gas-fired Frontloaders from the KG series comprise several models with kiln volumes between 250 and 1000 litres. These kilns were designed for use in workshops. Based on electric frontloaders, the entire steel construction is equipped with in-frame ventilation made of stainless steel sheets. The "System ROHDE" R-SiC ceiling support prevents cracks and particles falling from the ceiling onto the ware.

Downdraft flame control technology ensures even temperature distribution also in the KG series. The extremely silent high-performance intermediate pressure burners were developed specially for gas-fired ROHDE Frontloaders. They ensure an optimal temperature rise even in the high temperature range. The gas fittings including safety technology are pre-installed for connection to gas bottles or gas lines according to DVGW (DVGW German Technical and Scientific Association for Gas and Water). A thermocouple with temperature meter is supplied with the kiln.

You can choose the ROHDE Servo Jet equipment for firing a Frontloader from the KG series with natural gas.

Special features of the KG series:

- Downdraft flame control technology
- Stainless steel in-frame ventilation resulting in low external temperatures and corrosion protection
- Stainless steel hood
- Flame baffle plate to protect the kiln construction in the burner area
- Exhaust air handle setting using a guiding scale

Special equipment:

- Oxygen probe for atmospheric measurement
- CO alarm and monitoring device
- ROHDE Servo Jet equipment for working with natural gas
- Castors, stable and robust



KG 500 A



Gas Frontloaders **KG** series to 1320°C

Model	Tmax	Int. dimensions mm			Ext. dimensions mm			Output	Burners	Furniture batts	Weight
		Volume	°C	w	d	h	W				
KG 250 A	1320	540	670	760	1190	1035	1880*	40	2	600 x 500	590
KG 340 A	1320	700	760	760	1510	1240	1880*	80	4	550 x 340 (2)	800
KG 500 A	1320	610	870	980	1420	1360	2210*	80	4	560 x 380 (2)	900
KG 750 A	1320	830	890	1140	1640	1390	2360*	80	4	400 x 400 (4)	1020
KG 1000 A	1320	830	1050	1210	1640	1550	2440*	120	6	480 x 400 (4)	1250

* incl. detachable stainless steel hood

Raku Toploaders TR Series

ROHDE Toploaders from the TR series for Raku applications stand for easy handling, durability and flexibility. Toploaders from the TR series are trouble-free to transport and easy to handle. High standard technology such as a V2A stainless steel jacket or a stable structure made of lightweight firebricks guarantee sturdiness and long service life.

ROHDE Toploaders from the TR series have very low energy consumption at remarkably short heating rates. For this purpose, ROHDE developed a silent 30 kW high-performance burner that is easy to regulate especially for this series.

All models of the TR series can be disassembled into ring segments for transport. Benefit from the extendability of the model TR 80 Vario by fitting in an extension ring for more flexibility.

Special features of the TR series:

- Lid easy-to-open supported by gas pressure springs (not for TR 80 Vario)
- Reduction-resistant lightweight firebrick lining of the firing chamber
- Sturdy kiln frame with handles allowing effortless transportation
- ROHDE Raku burner equipment for use with propane and butane gas, powerful and silent
- View port to monitor firing

Complete Raku burner kit:

- Atmospheric 30 kW Raku burner for use with propane gas
- Hose connection including pressure control and manometer for connection to bottle
- Digital temperature meter up to 1150°C (battery-operated)
- Thermocouple NiCr/Ni NL 130 to 1150°C

Special equipment:

- Castors, stable and robust



TR 80

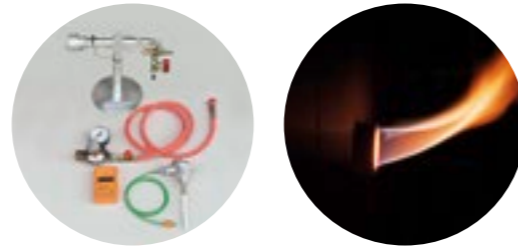

Raku Frontloaders KR Series

This kiln series combines high-level Raku technology with all the advantages of a frontloader. The V2A stainless steel jacket and side wall structure made of lightweight firebricks guarantee extreme sturdiness and a long service life. The material used in the kiln door and back is free of ceramic fibre, thus reducing weight. Thanks to a remarkably handy construction, the kiln door opens easy and wide even when using commercial Raku gloves.

Special features of the KR series:

- Reduction-resistant lightweight firebrick lining of the firing chamber
- Kiln door and back made in ceramic fibre module design
- Sturdy kiln frame allowing effortless transportation
- ROHDE Raku burner equipment for use with propane and butane gas, powerful and silent

Complete Raku burner kit:

- Atmospheric 30 kW Raku burner for use with propane gas
- Hose connection including pressure control and manometer for connection to bottle
- Digital temperature meter up to 1150°C (battery-operated)
- Thermocouple NiCr/Ni NL 130 to 1150°C

Special equipment:

- Drying rack, handy and practical
- Castors, stable and robust



KR 70



Raku Toploaders **TR** series to 1150°C

Model	Volume	Tmax °C	Int. dimensions mm			Ext. dimensions mm			Output kW	Burners Quantity	Furniture batts w x d mm	Weight kg
			w	d	h	W	D	H				
TR 44		1150	400	400	350	620	650	790	30	1	350	60
TR 80		1150	460	460	610	620	620	840	30	1	350	80
TR 80 vario		1150	460	460	610	620	620	840	30	1	350	80
ZWR 80		–	460	460	230	620	620	230	–	–	–	24
TR 170		1150	610	610	580	620	850	920	30	1	540	120

ZWR = Extension ring to increase volume

Raku Frontloaders **KR** series to 1150°C

Model	Volume	Tmax °C	Int. dimensions mm			Ext. dimensions mm			Output kW	Burners Quantity	Furniture batts w x d mm	Weight kg
			w	d	h	W	D	H				
KR 70		1150	400	450	430	630	630	870	30	1	370 x 340	80
KR 150		1150	610	570	510	840	760	960	30	1	550 x 500	125

ROHDE LPG Pot Burner with 20 kW burner output for ceramic kilns to 1400°C

The powerful ROHDE burner for use with propane or butane gas offers very fine vertical flame adjustment.

The power is controlled using the pressure control at the ROHDE Hose Connection mounted to the burner system with a quick connector. The carefully selected control range of the ROHDE Pressure Reducer and an easy-to-read manometer allow high reproducibility of firing processes and low energy consumption. The optimised flame plate geometry ensures low noise levels and is ideal for use in workshop applications.

Technical characteristics:

- Rated power 20 kW
- Control ratio 1:15
- Pressure range: intermediate pressure range 0.1 to 1.5 bar
- Suitable for use with butane/propane gas (LPG)
- Standard flame igniter using piezoelectric igniter
- Permanent flame control using temperature sensor
- Primary air supply handle at the burner tube for fine adjustment

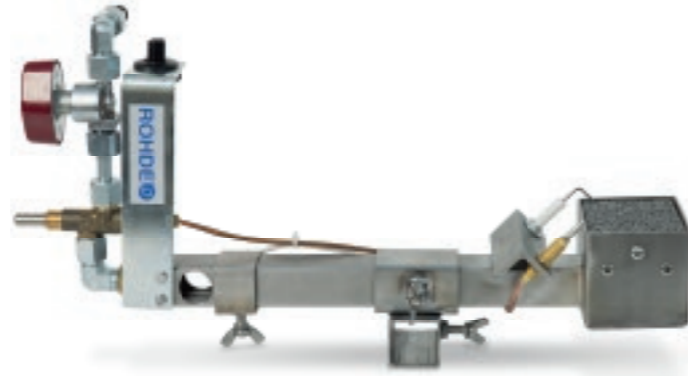

ROHDE Servo Jet Natural Gas Burner with 20 kW burner output for ceramic kilns to 1400°

The Servo Jet pot burner has been specially developed by ROHDE for use with natural gas in the low pressure range up to 25 mbar. During operation, the burner requires additional compressed air that is mixed with natural gas inside the burner tube. This is a powerful natural gas burner with vertical flame adjustment for very fine adjustment using gas or air pressure. Relevant operating elements such as flame igniter, safety and control valve, primary air supply handle and stop valve are clearly arranged and easily accessible ensuring safe operation.

Power is controlled by two operating elements: air pressure reducer and gas flow meter. Easy-to-read manometers allow high reproducibility of firing processes. The improved flame plate geometry ensures low energy consumption and low noise levels.

Technical characteristics:

- Rated power 20 kW
- Control ratio 1:10
- Pressure range: low pressure range to 25 mbar
- Standard flame igniter using piezoelectric igniter
- Permanent flame control using temperature sensor



ROHDE Raku Burner with 30 kW for Raku applications to 1150°C

The ROHDE Intermediate Pressure Burner for Raku applications features high performance with very low noise levels. Short heating rates and safe handling of gas components allow efficient firing processes with very low gas consumption.

The Raku burner is suitable for use with propane or butane gas and gas pressure allows fine adjustment and best possible control. Relevant operating elements such as safety valve, primary air supply handle and stop valve can be accessed easily and are clearly arranged for safe operation.

The power is controlled by the ROHDE Hose Connection that is mounted on the burner systems using a quick connector. The large control range of the ROHDE Pressure Reducer and easy-to-read manometer allow high reproducibility of firing processes.

Technical characteristics:

- Rated power 30 kW
- Control ratio 1:15
- Pressure range: intermediate pressure range 0.1 to 1.5 bar
- Suitable for use with butane/propane gas (LPG)
- Permanent flame control using temperature sensor
- Primary air supply handle on the burner tube for fine adjustment



Optional accessories for gas-fired and Raku Kilns



Digital oxygen sensor TM 100



Oxygen probe for atmospheric measurement



CO alarm and monitoring device



Thermocouple NiCr/Ni NL 130 to 1150°C



Castors, stable and robust



Stainless steel hood



Practical and easy-to-mount drying rack (KR series)



Complete Raku kit (Raku burner, pressure control, manometer, temp. meter, thermocouple)



LET'S CALL IT – GLASS.

Glass object by Susanne Sorg

ROHDE FUSING KILNS



Toploaders TE-MCC+ series with lid heating

The concept of these toploaders with lid heating is based on the proven design of the ROHDE Toploader TE-MCC+ series. They allow flexible use and, after extending with a heatable lid, are suitable for ceramic applications and glass processing such as Pâte-de-verre, glass casting, pre-heating or fusing.

The lid heating elements are mounted on high-quality support rods and are optimally fixed enabling free radiation of heat. The unique fixing of heating elements to the kiln lid prevents particles falling from the lid insulation and enables the use of the top furniture layer without restriction.

The lid heating can be switched on or off on request. When operated with a TC 504 or TC 507 controller, an optional automatic 2-zone control can be used. The kiln volume of ROHDE Toploaders with lid heating can be increased by fitting in an extension ring. This allows operation of the lid heating or the extension ring.

Benefit from a ROHDE Toploader of the TE-MCC+ DH series for your applications and discover the numerous varieties of thermal glass processing.



TE 75-MCC+ DH

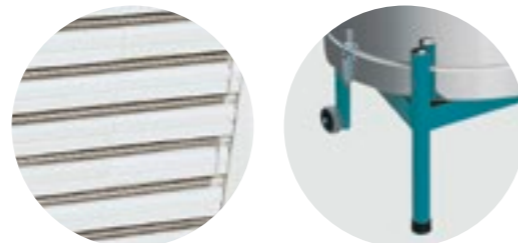

Lid heating mounted on support rods

Reversible kiln stand, handy and practical

Electric Toploaders TE-MCC+ DH series to 1320°C

Model	Tmax	Int. dimensions mm			Ext. dimensions mm			Output	Supply	Connector	Furniture batts	Weight
Volume	°C	w	d	h	W	D	H	kW	A	Plug	w x d mm	kg
TE 75 MCC+ DH	1320	ø 470	460	770	820	820	9,0	13	CEE 16 A	ø 410	82	
TE 100 MCC+ DH	1320	ø 520	460	810	860	820	10,5	15	CEE 16 A	ø 470	89	
TE 130 MCC+ DH	1320	ø 590	460	870	940	820	8,8	16	CEE 16 A	ø 540	106	
TE 200 MCC+ DH	1320	ø 740	460	1000	1050	820	12,5	20	CEE 32 A	Cut to size	130	

Special voltage electric supply for all EU networks available on request

Fusing Kilns Fusing 40 and Fusing 230

The concept of ROHDE Fusing kilns is based on proven ROHDE Toploader Kiln building technology which has been continually developed for 35 years. The models Fusing 230 and Fusing 40 are designed as tabletop models and are therefore suitable for integration into any workshop environment. This kiln concept consists of an integrated kiln controller providing the highest flexibility. With a storage capacity for 15 programs each with 15 segments, this controller covers almost any requirement in fusing applications and guarantees the best possible results.

Special features of the Fusing series:

- Insulation structure made of lightweight firebricks, free of ceramic fibres
- High-quality infrared radiators
- Low external temperatures at maximum temperature 950°C
- Power control effected by silent, low-wear solid-state relays with an external cooling element
- Lid easy-to-open supported by gas pressure springs
- Comfortable and compact kiln control, integrated into kiln body

Controller TC 2088e

- Saves up to 15 programs
- Each program with 15 segments
- Clear and easy-to-read display
- Additional switch outputs optional e.g. for signalling devices etc.
- Intuitive operating layout, modern design
- USB interface optional for WinConfig and WinControl

Controller TC 2088e

Pressure spring-supported opening mechanism for the lid



Fusing 230



Fusing 40



Electric Fusing Kilns Fusing series to 950°C

Model	Tmax	Int. dimensions mm			Ext. dimensions mm			Output	Supply	Connector	Volume	Weight
Volume	°C	w	d	h	W	D	H	kW	A	Plug	Liter	kg
Fusing 40 L	950	500	400	210	850	650	510	2,9	13	Schuko	42,0	70
Fusing 40	950	500	400	210	850	650	510	3,6	16	Schuko	42,0	70
Fusing 230	950	1020	660	320	1350	1100	630	11,0	16	CEE 16 A	218,4	170

Special voltage electric supply for all EU networks available on request

Fusing Kilns FE series

ROHDE Fusing Kilns from the FE series guarantee high-level kiln technology. Modern construction principles and the use of high-quality materials allow safe and effective processing of glass. The entire steel construction of the FE series has been designed to be resistant to distortion and its stainless steel components can be exposed regularly to heat.

The flexible FE series is equipped with a kiln frame on stable and sturdy castors (fixed to the kiln stand for models FE 75/100) allowing good workshop organization. The hoods on models FE 75 to 1000 are provided with gas pressure springs that allow safe, easy opening of the lids. You can choose an optional electrically operated lid opening for all ROHDE Fusing Kilns from the FE series.

The insulation structure of ROHDE Fusing Kilns consists of a solid work surface made of insulating bricks combined with a high-quality manufactured fibre lid. ROHDE ensures that the fibres used have abrasion resistant surfaces to prevent particles falling from the ceiling or contaminating the ware. View ports are installed in the side walls preventing particles falling from the ceiling while the lid is open and offering the best possible overview of the entire firing surface.

The model FE 1800 has been designed as hood kiln in portal construction. The kiln hood is lifted vertically using a manual device thus allowing easy handling of large-surface workpieces and positioning of compact elements on the entire firing surface. After lifting the hood, the worktable can be moved freely. The lifting movement can be operated using an optional hydraulic mechanism.

All ROHDE Fusing Kilns from the FE series are equipped with high-quality infrared quartz radiators. Power is controlled by silent, low-wear solid-state relays. Benefit from this combination of fibre insulation, heating with quartz radiators and power control using solid-state relays to obtain exact and safe firing control for your applications and at the same time the best possible results.



FE 100 N/S with optional kiln stand



FE 250



FE 600

Hinge and opening mechanism, stable and robust



Pressure spring-supported opening mechanism for the lid

Large, practical lid handle with extension enabling easy and safe work processes

High-quality quartz radiators resulting in effective and even heat distribution

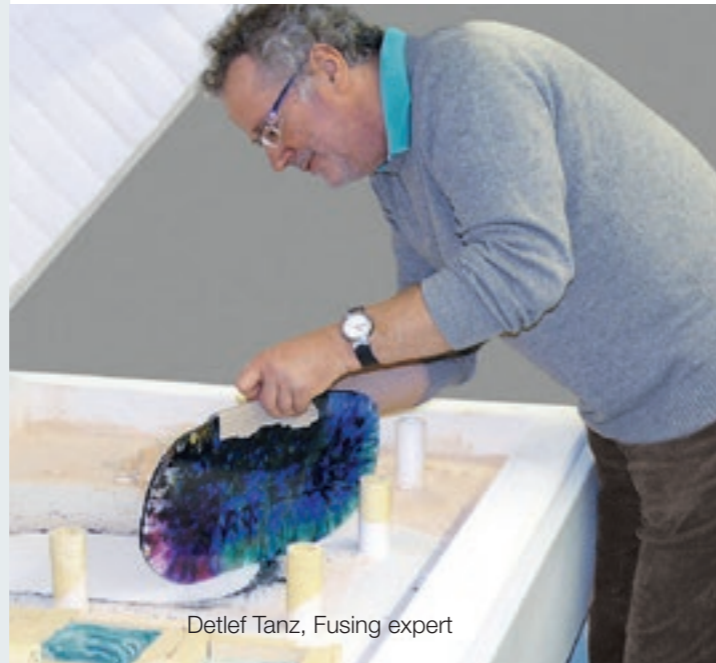

Detlef Tanz, Fusing expert

Electric Fusing Kilns FE series to 1000°C

Model	Tmax	Int. dimensions mm			Ext. dimensions mm			Output	Supply	Connector	Working height	Weight
Volume	°C	w	d	h	W	D	H	kW	A	Plug	Top edge mm	kg
FE 75 *	1000	520	520	300	830	980	560	3,6	16	Schuko	350	160
FE 100 S *	1000	520	520	380	810	980	560	7,0	10	CEE 16 A	350	190
FE 250	1000	1100	600	410	1440	1170	1370	11,0	16	CEE 16 A	800	400
FE 460	1000	1200	950	410	1630	1550	1500	11,0	16	CEE 16 A	800	430
FE 600	1000	1700	850	410	2160	1470	1400	15,0	22	CEE 32 A	800	540
FE 1000 N	1000	2200	1200	410	2590	1870	1370	22,0	32	CEE 32 A	800	800
FE 1000 S	1000	2200	1200	410	2590	1870	1370	30,0	43	CEE 63 A	800	800
FE 1800 **	1000	3050	1550	410	3500	1900	1900	43,0	63	CEE 63 A	800	1600

*Tabletop models (optional kiln stand) **Designed as hood kiln

CONTROL YOUR **BEST POSSIBLE RESULTS.**

ROHDE CONTROLLERS



Kiln Controller TC 304

Range of application:
Ceramics, laboratory

Clearly structured control unit and easy to operate, for use in workshops, schools and hobby rooms.

- 5 firing programs, freely adjustable
- Delayed start programmable
- 1 dwell/soak time freely programmable



Kiln Controller TC 504

Range of application:
Ceramics, laboratory, heat treatment

High-performance control unit with the highest security standard and high comfort suitable for demanding workshop and laboratory applications. Equipped with 2- or 3-zone control (optional).

- 10 firing programs, freely adjustable
- Delayed start programmable
- 2 dwell/soak times freely programmable
- 1 additional switch output



Kiln Controller TC 88e

Range of application:
Ceramics, laboratory, heat treatment, fusing

High-performance compact control unit with flexible adjustment of programs with up to 15 consecutive segments. Works reliably with highest possible safety in glass, metal and ceramic applications.

- 15 firing programs, freely adjustable
- Delayed start programmable
- Up to 15 segments freely programmable



Kiln Controller TC 507

Range of application:
Ceramics, laboratory, heat treatment, fusing

High-performance 30-segment control unit with the highest safety standards and many special features. Suitable for demanding workshop and laboratory applications, as well as glass fusing. Equipped with 2- or 3-zone control (optional).

- Up to 30 firing programs, freely adjustable
- Delayed start programmable
- Up to 30 segments freely programmable
- 2 additional switch outputs (optional)



Kiln Controllers TC 304 and TC 504 series

Technical data	TC 304	TC 504
Control range / Steps	0-1320°C / 1°C Steps	0-1320°C / 1°C Steps
LED display Setpoint value	4 digits	6 digits
LED display Actual value	4 digits	6 digits
Display of units	•	•
Display of firing stages	•	•
Event control	-	For possible configurations, please see valid price list.
Zone control	-	
Error message	•	•
Safety lock	-	•
Display electricity consumption	-	•
Protection against over-temperature	•	•
Optional printer port	-	•
Programs	5 free	10 free
Segments	2	2
Program delay	0:00-9:59 h	0:00-99:59 h
1. heating rate	1-999°C / h and Full	1-999°C / h and Full
Switch point	20-1320°C	20-1320°C
1. dwell time	-	0:00-99:59 h
2. heating rate	1-999°C / h and Full	1-999°C / h
2. dwell time	0:00-9:59 h	0:00-99:59 h
Cooling down rate	1-999°C / h and Full	1-999°C / h
Size (w x l x h) / Weight	80 x 153 x 22 mm / 340g	110 x 220 x 60 mm / 450g

Kiln Controllers TC 88e and TC 507 series

Technical data	TC 88e	TC 507
Control range / Steps	0-1320°C / 1°C Steps	0-1320°C / 1°C Steps
LED display Setpoint value	4 digits	6 digits
LED display Actual value	4 digits	6 digits
Display of units	-	•
Display of firing stages	•	•
Event control	-	For possible configurations, please see valid price list.
Zone control	-	
Error message	•	•
Safety lock	-	•
Display electricity consumption	-	•
Protection against over-temperature	•	•
Optional printer port	-	•
Programs	15 free	98 free
Segments	15	48
Program delay	0:00-9:59 h	0:00-99:59 h
1. heating rate	20-1320°C / h and Full	1-999°C / h and Full
Switch point	20-1320°C	20-1320°C
1. dwell time	0:00-9:59 h	0:00-99:59 h
2. heating rate	20-1320°C / h and Full	1-999°C / h
2. dwell time	0:00-99:59 h	0:00-99:59 h
Cooling down rate	20-1320°C / h	1-999°C / h
Size (w x l x h) / Weight	65 x 110 x 60 mm / 350 g	110 x 220 x 60 mm / 450g

Panel-mounted Compact Controller JUMO dTRON

High-performance panel-mounted control unit with the highest security standard and high operating comfort. Clear presentation of actual and setpoint values in demanding workshop and laboratory applications.

- Compact controller can be integrated into the kiln casing, saving space
- Including ramp function, timer start, manual mode
- Configurable user level enables setting of the most important parameters
- Individual controller optimisation to adjust to kiln requirements
- Clear presentation of actual and setpoint values



Panel-mounted Compact Controller Bentrup TC 2088

High-performance panel-mounted control unit with the highest security standard and high operating comfort. Clear presentation of actual and setpoint values in demanding workshop and laboratory applications.

- Units displayed on easy-to-read LED display (actual and setpoint values)
- Clear and easy-to-read display, intuitive operating layout
- 15 freely programmable firing programs, 2 segments each
- Available with zone control
- Program time delay or program start delay can be adjusted
- Optional additional switch outputs e.g. for signal sensors etc.



Panel-mounted Comfort Controller JUMO Dicon Touch

Universal process and program controller using brilliant TFT colour graphic screen visualisation, intuitive to operate with touch screen

- Alphanumeric display saves 10 programs with up to 50 program segments, 2 events (e.g. air supply handle and exhaust air control) individually programmable
- Clear presentation of relevant process values
- Integrated paperless recorder, tamper-resistant data storage
- Process data can be collected using USB stick or Ethernet connection and exported to the PC using software
- Integrated timer and time switch for program start
- Available as completely attachable controller



Panel-mounted Comfort Controller JUMO IMAGO 500

- Easy and intuitive to operate, back-lit 5" colour graphic display with multi-channel program and process control with up to 50 programs and 1000 program segments
- Clear presentation of figures, symbols and texts, bargraph display and colours
- Program start programmable using real time clock
- Up to 8 control channels available
- Evaluation of firing curve data on the PC using RJ 45 or RS 485 by PCA user software and PCC communication software



Solutions for network and data storage

Compliance with quality management guidelines often requires documentation of production process values. Data storage systems that are reliable and easy to handle allow these requirements to be met.

Paperless Recorder JUMO LOGOSCREEN nt

- Easy-to-operate rotary knob
- Presents measured values on different diagrams
- Detailed batch reporting
- Including 5.5" TFT colour graphics screen, Ethernet connection and integrated web server
- Evaluation of firing curve data on the PC using RJ 45 or RS 485 by PCA user software and PCC communication software



Professional Controller SIEMENS PLC S7-1200 with Panel TP 700 Comfort

- 7" touch screen panel for programming and optimal presentation of program curves
- ROHDE user interface, individually programmable to suit your requirements
- Evaluation of firing curve data on the PC using MS Excel
- Profinet interface for direct network integration, remote control optional

Data storage and PLC control

- Stores process values and firing data (batch denomination, program number etc.) on USB interface
- Saves data in CSV format for further processing with MS Excel



ROHDE MACHINERY AND EQUIPMENT



Pottery Wheel HMT 500

The HMT 500 has been designed for everyday use in potters' workshops. The high-performance ROHDE machine combines modern control and drive technology with excellent ergonomics that can be integrated into any individual workshop routine.

The outstanding variety of ergonomic settings of wheel and seat guarantee individual working allowing unlimited creativity. The quiet and high-torque drive ensures perfect work procedures even under the highest load. The robust and highly durable ROHDE HMT 500 offers unlimited possibilities.

Special features of the HMT 500:

- Aluminium wheel head, diameter 340 mm
- Wheel head equipped with device for quick change MDF wooden batts
- Quiet and powerful high-torque drive, foot pedal for flexible and individual speed adjustment
- Left and right drive
- Working height adjustable from 550 to 690 mm
- Seat adjustable in height, inclination and distance to wheel
- Including large splash pan, easy to remove and with lockable drain outlet



Pan with 340 mm turntable

Working height adjustable from 550 to 690 mm

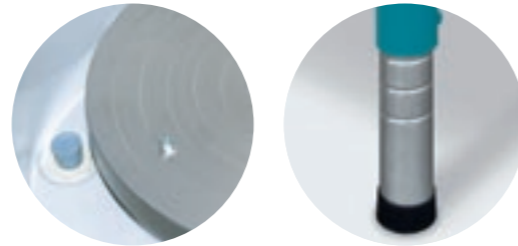

Pottery Wheel HMT 500

Model	Ext. dimensions mm			Output W	Voltage V	Supply A	Speed rpm	Weight incl. seat kg
	W	D	H					
HMT 500	530	1200	550	370	230	2,0	0-250	46

Pugmill TS 20

The ROHDE Pugmill TS 20 stands for robust, durable construction and excellent performance. The machine is highly suitable for kneading of ceramic bodies prior to further processing, mixing of different bodies and preparation of waste clay. The pugmill enables very good preparation of plastic mixes and gives them a high degree of workability for further processing.

The mixing barrel, mixing shaft fitted with wing blades and all other machine components that come into contact with clay are made of stainless steel. The vertical design and the large feeder allow easy top loading of the TS 20. A split body for disassembly facilitates easy cleaning. Two castors and two fixed machine feet guarantee mobility and a firm stand. The tray unit and cutting device are detachable; the aluminium nozzle is fitted with threads to fix extruder dies.

Special features of the TS 20:

- Large stainless steel mixing barrel (diameter 235 mm)
- Aluminium die (diameter 80 mm) with plastic lining
- Clay throughput up to 600 kg/hour
- Split barrel facilitates easy and safe cleaning
- Working table fitted with device to divide into portions
- Safety unit for automatic switch-off



Barrel, shaft and blades made of stainless steel

Outstanding clay preparation

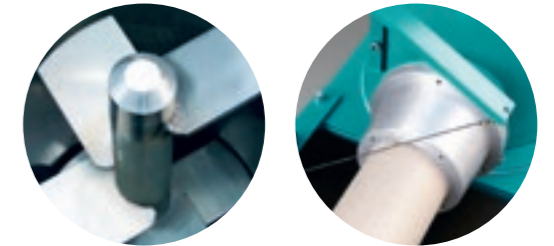

Pugmill TS 20

Model	Ext. dimensions mm			Output W	Voltage V	Supply A	Speed Rpm	Weight kg
	W	D	H					
TS 20 / 400 V	540	1100	1070	1100	400	3,0	15	105
TS 20 / 230 V	540	1100	1070	1100	230	7,2	15	105

Slab Roller PW 600

The ROHDE Slab Roller PW 600 is a very robust and high-quality machine for rolling plastic ceramic bodies and is extremely easy and safe to handle.

The PW 600 frame construction is made of strong, high-quality welded square tubes that provide the highest resistance to distortion. The four fixable plug-in feet can be disassembled for transport allowing it also to be used as a tabletop slab roller.

The clay body is fed in between two sturdy linen cloths for rolling. The large roller diameter and the smooth-running wheel handle allow the slab to be fed easily through rollers across the entire workspace. The thickness indicator allows the thickness of the slab to be precisely and continually adjusted from two sides. Guided by high-quality grooved ball bearings, the roller slide runs over a smooth, stainless steel roller table. This ensures the highest precision in everyday use in workshops and schools.

Clay slabs can be removed from the slab roller without effort and are then ready for further processing. The ROHDE PW 600 does not require elaborate cleaning.

Special features of the PW 600:

- Large workspace (650 x 850 mm) providing good overview
- Continuous setting of thickness (up to 85 mm) from two sides, easy-to-read scale
- Precise movement of roller using 8 ball bearings on stainless steel roller table
- 2-layer industrial linen cloth, easy cleaning
- Roller diameter 100 mm
- Large wheel handle facilitates operation



Slab Roller PW 600

Model	Usable dimensions mm			Ext. dimensions mm			Weight kg
	w	d	h	W	D	H	
PW 600	650	850	0-85	880	1410	1250	100

Spray Booth SK 66

The ROHDE Spray Booth SK 66 has been specially designed for applications in the ceramic manufacturing process. It prevents fine glaze and colour particles from escaping into the air and guarantees dust-free and safe working in the entire workshop.

The SK 66 is outstanding in its sturdy and functional assembly. The corrosion-free booth made of shockproof plastic material ensures the particularly silent, smooth and high-performance operation of this unit.

The ROHDE filter system is integrated into the exhaust device and can be easily cleaned or changed without using tools and prevents toxic colour and glaze particles from escaping into the air. The SK 66 guarantees high safety, excellent ergonomics, low noise levels at high performance level and can be easily accessed for cleaning.

Special features of the SK 66:

- Booth made from 8 mm shockproof polypropylene plastics, no corrosion
- Filter integrated in baffle wall, easy to remove and wash
- Easy clean-up of machine
- Vacuum fan, silent and powerful

Optional accessories:

- Piece for reduction, diameter 150 mm
- Turntable (banding wheels)

Powerful fan allowing for high air movement

Both stand steel constructed, galvanised and lacquered, easy to fit



Spray Booth SK 66

Model	Usable dimensions mm			Ext. dimensions mm			Volt	Watt	Hz	Fan Volume flow	Weight kg
	w	d	h	W	D	H					
SK 66	670	520	750	790	790	1700	230	330	50	1540 m³/h	42

Banding Wheels RSN/RSH and RSSN/RSSH

ROHDE Banding Wheels are professional appliances that are extremely versatile in the ceramic manufacturing process. They are characterised by a particularly high quality standard and allow the flexibility that is required for the precise processing of a workpiece.

All ROHDE Banding Wheel models stand for high-quality workmanship, durability and smooth and silent rotation. The turntable surface is grooved with concentric circles for centring which enables precise positioning of the workpiece. The turntables of models RSN and RSH rotate on a minimal contact point on a hardened steel ball resulting in a remarkably long rotation time. Both models can be locked at any position with a set screw.

The two larger models RSSN and RSSH are made of high-quality grey cast iron that guarantees remarkable robustness allowing the processing of pieces up to 100 kilos. The turntables of the models RSSN and RSSH rotate on two grooved ball bearings which results in a particularly smooth and long rotation time allowing for precise treatment of the workpieces.

Special features of banding wheels:

- Precise workmanship and high-quality lacquering
- Smooth, silent rotation
- Models RSN and RSH can be fixed with wing screw
- Models RSN and RSH with turntable diameter 220 mm
- Models RSSN and RSSH with turntable diameter 260 mm
- Turntable grooved with concentric circles for centring



Banding Wheels for Standing Operation SRS and SRS H

ROHDE Banding Wheels for Standing Operation are all-purpose tools for professional use in ceramic workshops and are available for the first time on the European market. The banding wheels can be adjusted in height and are very heavy, which gives them an outstanding stability.

The turntable rotates on a ball bearing resulting in a remarkably long and smooth rotation time. It is possible to lock the turntable in any position with a set screw and to adjust its height continuously ensuring ergonomic working.

ROHDE Banding Wheels for Standing Operation can be used for a variety of applications. They facilitate many work processes that require high precision and concentration such as sculpting, carving or decorating of ceramics. Benefit from this robust and durable appliance and enjoy your results.

Special features of banding wheels for standing operation:

- Solid and stable
- Continuous height adjustment
- Turntable can be locked
- Cast iron leg gives stability
- Turntable diameter 220 or 280 mm
- Height adjustment section SRS 220 / 280: 650 – 950 mm
- Height adjustment section SRS 220 H / 280 H: 1000 – 1300 mm



Ergonomic fixing handle allows for continuous height adjustment

Turntable rotates precisely on ball bearing resulting in smooth rotation



Banding Wheels RSN / RSH and RSSN / RSSH

Model	Height mm	Diameter mm	Weight kg
RSN 220 lacquered	60	220	3,0
RSH 220 lacquered	155	220	3,5
RSSN 260 lacquered	60	260	6,0
RSSH 260 lacquered	140	260	7,0

Banding Wheels for Standing Operation SRS and SRS H

Model	Height mm	Diameter mm	Weight kg
SRS 220	650- 950	220	15
SRS 220 H	1000-1300	220	16
SRS 280	650- 950	280	16
SRS 280 H	1000-1300	280	17

Sedimentation Basin AB 100

The ROHDE Sedimentation Basin AB 100 is the ideal support for environmental awareness in the ceramic workshop. Glazes, clays and engobes are effectively collected and removed from the wastewater before they reach the sewage system.

This appliance can be connected to practically any drain allowing for flexible use. It is delivered with a siphon and inlet socket, a cover is optionally available. The stable and shockproof basin made of environmentally sound polypropylene plastic is highly flexible due to a supporting steel construction mounted on 4 mobile castors.

The tank has a generous three-compartment system that prevents the blockage of pipes and leads to a reduction in environmental stress. After cleaning using a ROHDE Sedimentation basin, wastewater complies with local regulations for wastewater.

Special features of the AB 100:

- Generous three-compartment system
- Environmentally sound polypropylene plastic tank, stable and shockproof
- Variable connection of inlet socket (diameter 40 mm)
- 4 mobile castors
- Optional cover



Solid castors allow comfortable and safe handling

Can be mounted to practically any sink and washbasin



Sedimentation Basin AB 100

Model	Usable dimension mm			External dimensions mm			Weight kg
	w	d	h	W	D	H	
AB 100	425	610	415	450	630	520	13

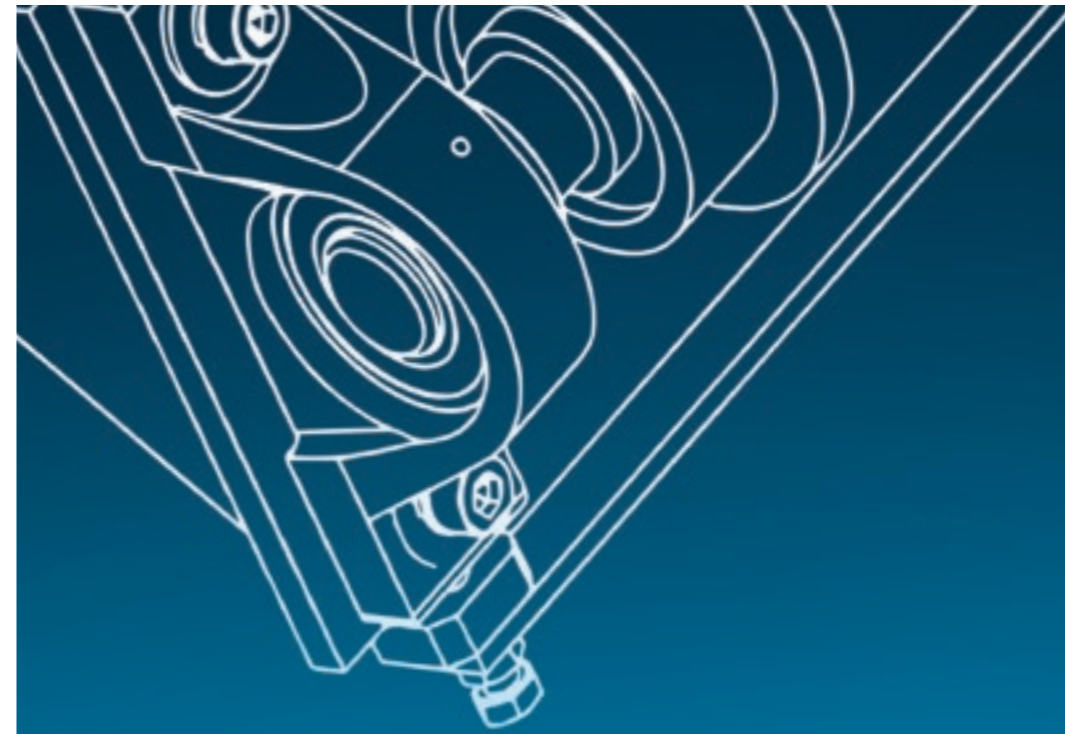

MISSION POSSIBLE.



Anything is possible. ROHDE provides the best solution for you either from its wide basic range of products or with a special customised construction. Contact ROHDE and see for yourself.

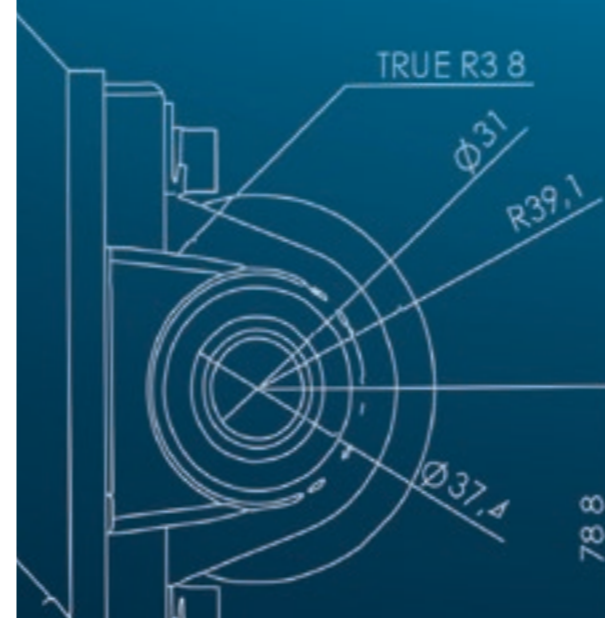

Delivery to a basement, second floor or through a window?

The ROHDE delivery service

ROHDE provides inexpensive, easy and safe delivery and set-up assistance for ROHDE kilns from a single source. The ROHDE delivery service provides safe on-site delivery of your kiln, including on-site instruction and initial operation by ROHDE experts if required. Full insurance from start to finish. Talk with ROHDE about your operating location.

Warranty and spare part service

ROHDE guarantees 3-year warranty (not on heating elements) on almost any ROHDE kiln and thermocouples. ROHDE and your local specialist are there for you when service is required.

ROHDE assures unlimited supply of spare parts. Spare parts are usually ready for dispatch one workday after receipt of order.

ROHDE always uses environmentally friendly materials and guarantees acceptance of each ROHDE product for recycling of reusable parts or environmentally sound disposal.

ROHDE is there for you

ROHDE is committed to personal service. Contact ROHDE by email or phone, whatever your needs. ROHDE employees are pleased to assist you at any time.



Delivery and set-up service



On-site instruction and initial operation



3-year warranty



Spare parts and service



Environmentally sound materials and recycling



COMMITTED TO SERVICE.

ROHDE  Enjoy your **results.**



For more information, please contact
your specialist trade partner, visit the
homepage or contact ROHDE directly.



Direct contact
using smartphone

03/2018
989312

ROHDE 

Helmut ROHDE GmbH
Ried 9
83134 Prutting, Germany
Phone +49 8036 674976-10
Fax +49 8036 674976-19
info@rohde-online.net
www.rohde-online.net